

## Formech FM660

The most popular manual vacuum forming machine



Forming area: **622mm x 622mm**

Depth of draw: **400mm**

Max material thickness: **6mm**

### Key features of the FM660

- **New generation FM660**

The world's most popular manual vacuum forming machine has now been superseded by our new generation FM660, incorporating a number of mechanical improvements and new features.

- **High specification**

A mid range, high specification, manual machine with an exceptional forming capacity, the FM660 produces mouldings of a size, thickness and quality unparalleled by any other machine of this size or price.

- **Ready to use in minutes**

With its fast warm up facility and full zone control the FM660 is ready for use in minutes, quickly producing prototype or production runs of components in a whole range of thermoformable materials.

- **Best seller**

Incorporating a digital timer with countdown, pre-stretch and autolevel facilities as standard features, the FM660 machine remains one of Formech's best selling units.

## Technical details Formech FM660

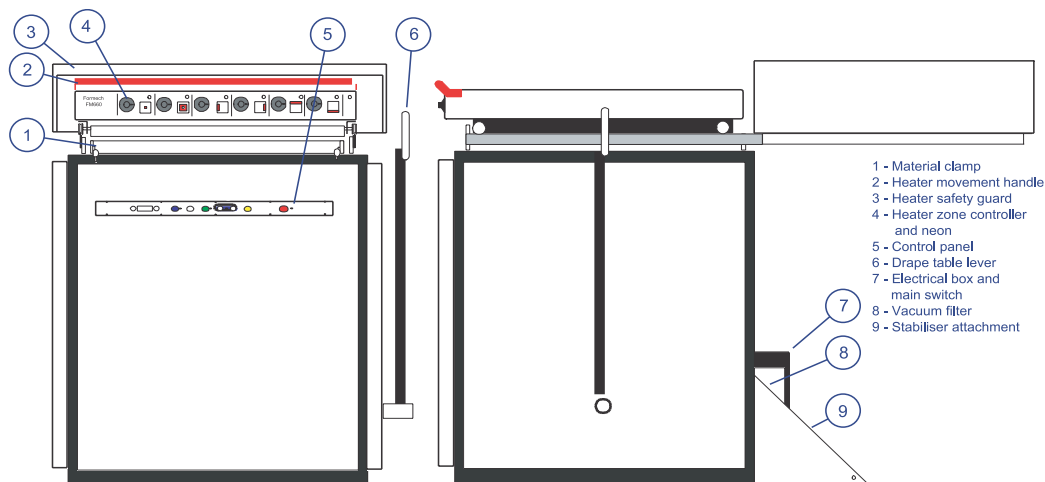

### Technical Specifications:

- Material size 660mm x 660mm
- Forming area 622mm x 622mm
- Max depth of draw 400mm
- Max material thickness 6mm
- Pre-stretch (requires air connection)
- Autolevel
- Digital timer function with countdown
- Overall width 940mm
- Overall height 1280mm
- Overall depth 1900mm
- Weight 260kg

### Electrical Specifications:

- 220 V / 240 V
- 50 / 60 Hz
- 7550W
- 3 phase optional (380 / 415V)

### Air Supply:

- 80 psi / 5 bar

### Options:

- Fast fit, thicker gauge reducing windows enables the operator to optimise plastic yield when working with smaller moulds
- Pneumatic table with jog facility on up and down stroke (reduces depth of draw to 300mm)
- Turbo cooling fan system (550W)
- Reel feed gantry
- Spare parts kit

### Other features:

- CE approved
- Fast warm up facility
- New touch sensitive control panel
- Improved element layout and increased zones (6)
- 10% overall increase in heater power
- Zinc plated, heat reflective clamp frame allows complete use of forming area
- Self adjusting rear clamp springs
- Heavy duty front toggle clamps
- New digital timer with countdown facility to ensure accurate heat cycles
- New, powerful, quiet 2 stage vacuum pump - 25" Hg
- Vacuum and pump filtering serviceability and easy access
- Front panel service access
- Improved heater movement
- Improved performance and durability of heater cabling
- Vacuum and release controls
- Designed for ease of maintenance - any parts can be changed in the minimum period of time
- Fast tool change facility - accepts moulds from clay, wood, resin, aluminium
- Easily maintained with 12 month warranty



**Formech  
International Limited**

Authorized Reseller :

Cimtech Inc.

tel: 253-333-0126

fax: 253-333-0127

e-mail: [info@multiaxis.com](mailto:info@multiaxis.com)

The Formech FM660 is from a wide range of products designed to suit a wide range of applications

**Formech**  
forming to perfection