

Formech Compac Midi

Compact, easily maintained and requiring minimum working space



Forming area: 430mm x 430mm
Depth of draw: 183mm
Max material thickness: 5mm

Key features of the Compac Midi

- **Powerful, economical and portable**
The Formech Compac Midi is a powerful, economical and portable manual vacuum forming machine capable of producing high quality plastic mouldings up to 5mm thick.
- **Easy to use**
Extremely easy to use with simple, accessible controls the Midi provides a fast sampling and small series back-up facility, avoiding the costly interruption of production equipment.
- **Competitive price**
Compact, easily maintained and requiring minimum work space, Formech offer this model at a very competitive price.

Technical details Formech Compac Midi

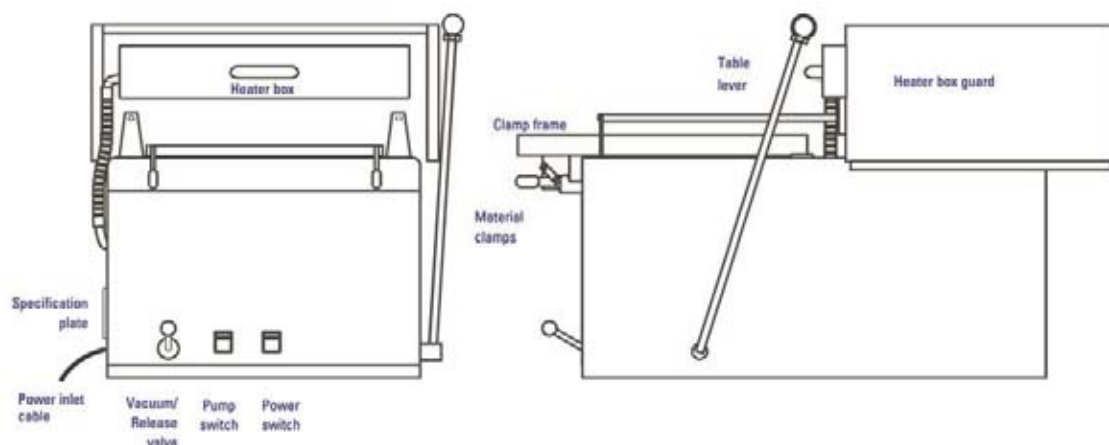

Technical Specifications:

- Material size 450mm x 450mm
- Forming area 430mm x 430mm
- Max depth of draw 183mm
- Max material thickness 5mm
- Overall width 800mm
- Overall height 600mm
- Weight 70kg

Electrical Specifications:

- 240 V, 13 amps, 50 Hz single phase
- 220 V, 13 amps, 60 Hz single phase
- 2.5 kilowatts
- 13 amp supply

Other Features:

- CE approved
- Heater movement track to prevent lifting and derailing of heater box during use
- Fast warm up facility
- Powerful infra-red ceramic heaters concentrically arranged to eliminate the need for pre-setting of zones
- Vacuum and release controls
- Designed for ease of maintenance - any parts can be changed in the minimum period of time
- Powerful two-stage vacuum pump - 25" Hg
- Fast tool change facility - accepts moulds from clay, wood, resin, aluminium
- Easily maintained with 12 month warranty

Options:

- Reducing windows
- Machine trolley
- Spare parts kit



Formech
International Limited

Authorized Dealer:

Cimtech Inc.

ph: 253-333-0126

fax: 253-333-0127

e-mail: info@multiaxis.com

The Formech Compac Midi is from a wide range of products designed to suit a wide range of applications

Formech
forming to perfection