

Formech Compac Mini

Compact and versatile, a highly adaptable machine requiring minimum working space



Forming area: **280mm x 230mm**
Depth of draw: **130mm**
Max material thickness: **4mm**

Key features of the Compac Mini

- **Entry level machine**
The Formech Compac Mini is the ideal entry level manual vacuum forming machine suitable for educational and prototype use.
- **Highly adaptable**
Its compact nature and versatility make the Compac Mini a highly adaptable machine requiring minimum work space.
- **Latest technology**
Incorporating the latest technology this safe, easy to use self contained unit can produce high quality plastic mouldings up to 4mm thick - all this for an exceptional price.

Technical details **Formech Compac Mini**

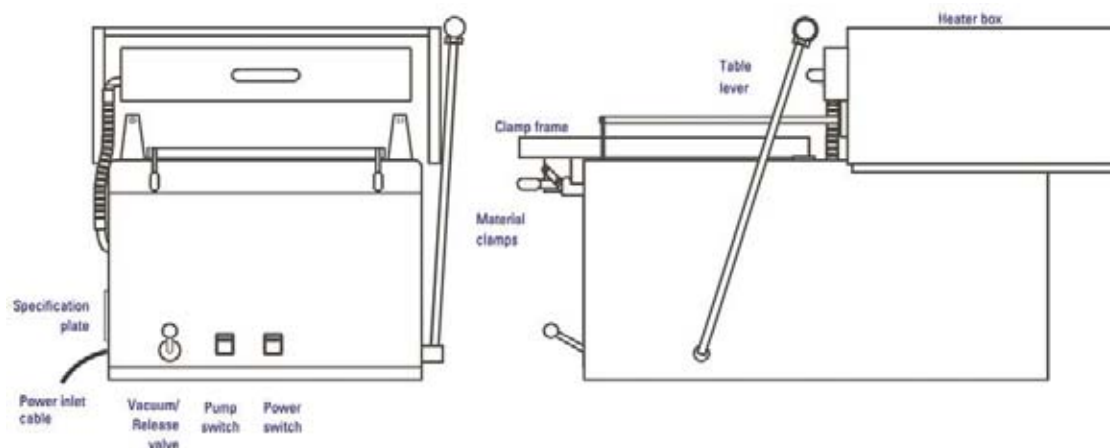

Technical Specifications:

- Material size 300mm x 250mm
- Forming area 280mm x 230mm
- Max depth of draw 130mm
- Max material thickness 4mm
- Overall width 420mm
- Overall height 420mm
- Overall depth 810mm
- Weight 35kg

Electrical Specifications:

- 240 V, 13 amps, 50 Hz single phase
- 220 V, 13 amps, 60 Hz single phase
- 750 watts
- 13 amp supply

Other Features:

- CE approved
- Interlocking table
- Heater movement track to prevent lifting and derailing of heater box during use
- Powerful infra-red ceramic heaters
- Vacuum and release controls
- Designed for ease of maintenance - any parts can be changed in the minimum period of time
- Two stage reciprocal diaphragm pump
- Fast tool change facility - accepts moulds from clay, wood, resin, aluminium
- Easily maintained with 12 month warranty

Options:

- Reducing windows
- Machine trolley
- Spare parts kit



Formech International Limited

Authorized Reseller:

Cimtech Inc.

tel: 253-333-0126

fax: 253-333-0127

e-mail: info@multiaxis.com

The Formech Compac Mini is from a wide range of products designed to suit a wide range of applications

Formech
forming to perfection